

- * Before using your SP-31, check that it is supplied with the following mounting parts:

■ ACCESSORIES

Speaker cord.....	E30-1711-15.....	1 ea.
1 pin plug.....	E14-0101-05.....	1 ea.
Instruction Manual.....	B50-8228-XX.....	1 sheet

After unpacking

Shipping container:

Save the boxes and packing in the event your unit needs to be transported for remote operation, maintenance, or service.

■ SPECIFICATIONS

Speaker used:	10 cm dia.
Rated Input:	2 Watts
Impedance:	8 Ω
Frequency response:	160 Hz to 7 kHz
Filter cut-off frequency:	
LOW:	400 Hz, -3 dB
HIGH 1:	3.0 kHz, -3 dB
HIGH 2:	1.2 kHz, -3 dB
HIGH 1 + HIGH 2:	900 Hz, -3 dB
Filter attenuation:	-6 dB/oct.
Dimensions:	
W.	180 mm (7-1/16")
H.	120 mm (4-23/32")
D.	310 mm (12-7/32")
Net weight:	2.0 kg (4.4 lbs)

■ FRONT FEET

The front panel can be elevated for operating convenience by extending the front feet. Turn the front feet left and pull down. Then turn right to lock.

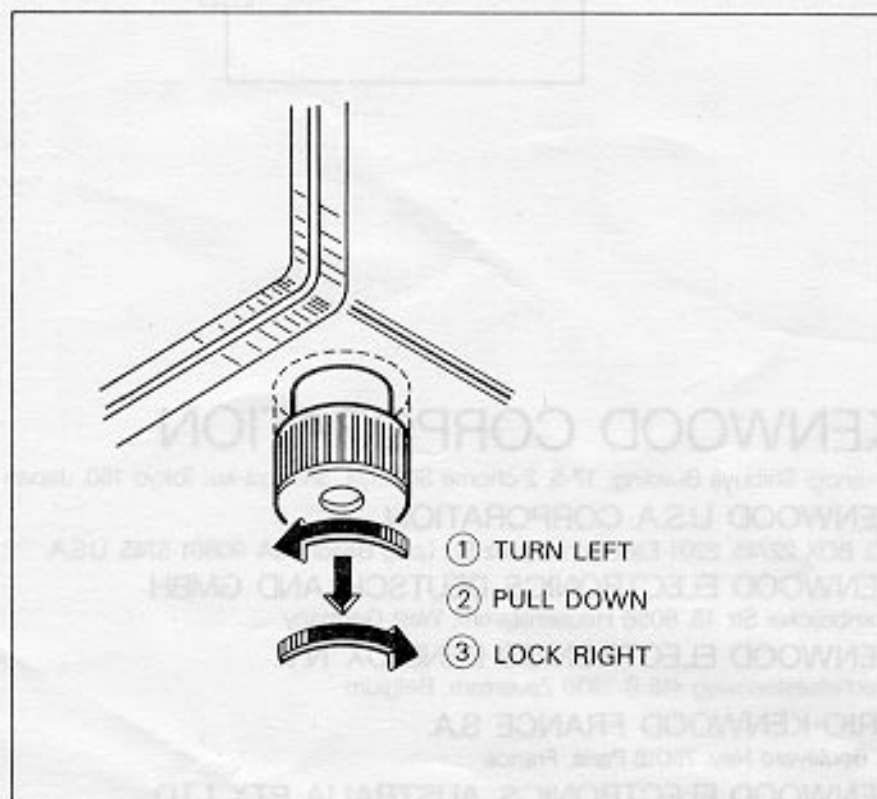

■ CONTROLS AND THEIR FUNCTION

Front Panel

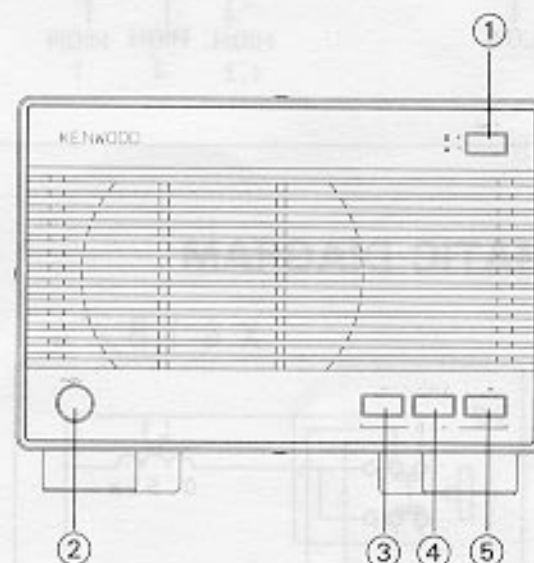

- ① **INPUT Switch**
Selects one of two audio inputs.
 - ② **PHONES Connector**
Standard headphone output, through the tone filters.
 - ③ **FILTERS, HIGH 1 Switch**
This switch attenuates frequencies above 3.0 kHz; -3 dB at 3.0 kHz.
 - ④ **FILTERS, HIGH 2 Switch**
This switch attenuates frequencies above 1.2 kHz; -3 dB at 1.2 kHz.
 - ⑤ **FILTERS, LOW Switch**
This switch attenuates frequencies below 400 Hz; -3 dB at 400 Hz.
- Note:** When this switch is used with the HIGH 1 and HIGH 2 ON, frequencies above 900 Hz; -3 dB at 900 Hz are attenuated.

Rear Panel

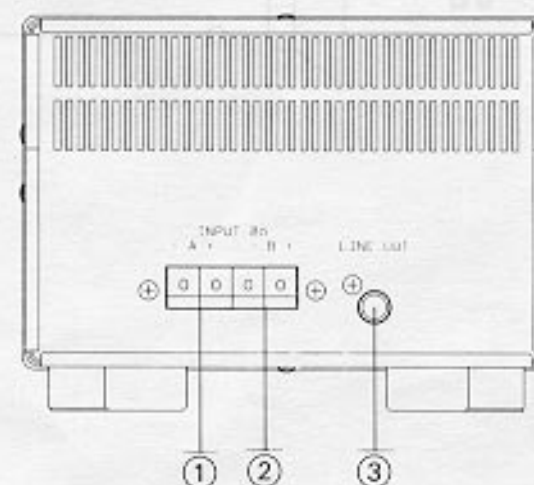

- ① ② **INPUT Connectors**
Accepts audio output from two sources.
- ③ **LINE OUT Connector**
Standard line output through the filters for RTTY, SSTV, or similar use.

USING COMBINED FILTERS

1. When both HIGH 1 and LOW filters are engaged, the pass bandwidth ranges from 400 Hz to 3.0 kHz.
2. When both HIGH 2 and LOW filters are engaged, bandwidth is 400 Hz to 1.2 kHz.
3. HIGH 1, HIGH 2 and LOW filters are engaged, bandwidth is 400 Hz to 900 Hz.

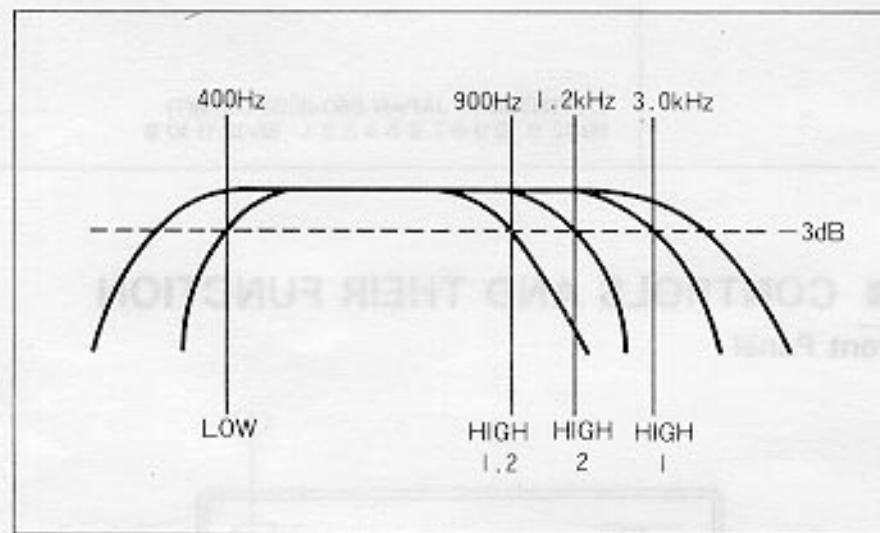

■ SCHEMATIC DIAGRAM

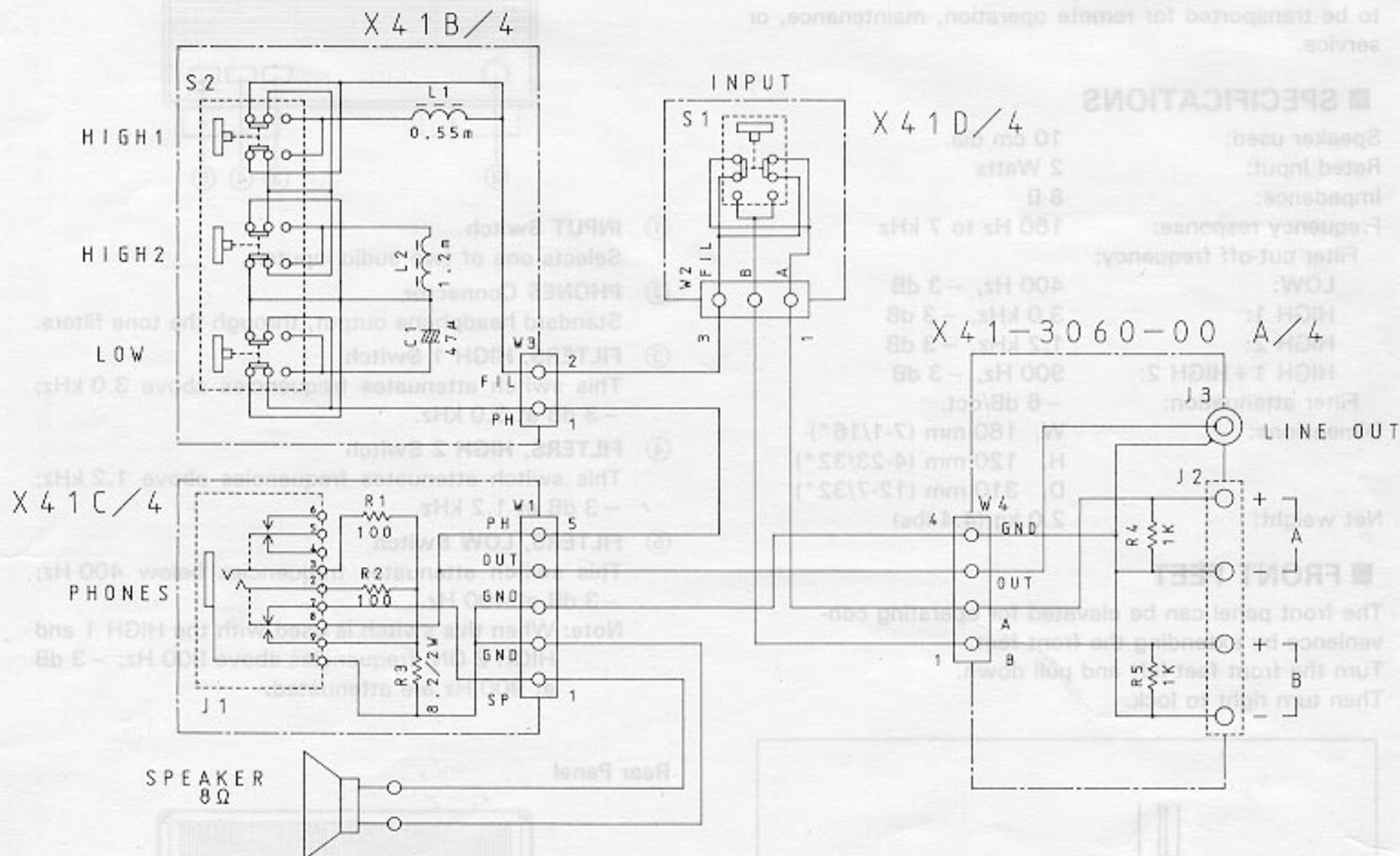

■ USE OF FILTERS

In general, it is desired that a CW, AM, or similar transmission be received clearly within the usual communication audio bandwidth, 400 Hz ~ 3 kHz. However, QRM, QRN or RFI may lower the overall signal-to-noise ratio at the receiver, resulting in degraded reception. In theory, as the pass-band width of the IF stages is narrowed, the equivalent noise bandwidth will also narrow, thus improving the signal-to-noise ratio. Alternately, the bandwidth of the AF stage can be narrowed to attenuate the noise component, enhancing reception.

Proper filter selection depends on transmission mode and type of noise encountered.

1. **SSB:** use the HIGH 1 and LOW filters, or the HIGH 2 and LOW filters. In more severe cases, use both HIGH 1 + HIGH 2, and LOW filters.
2. **CW:** use the HIGH 1 and HIGH 2 filters or HIGH 1 + HIGH 2 and LOW in combination.